

**CONFIGURATION**

<b>X</b> Control	-
<b>C</b> Cracking Pressure	29 psi (2.0 bar)
<b>N</b> Seal Material	Buna-N

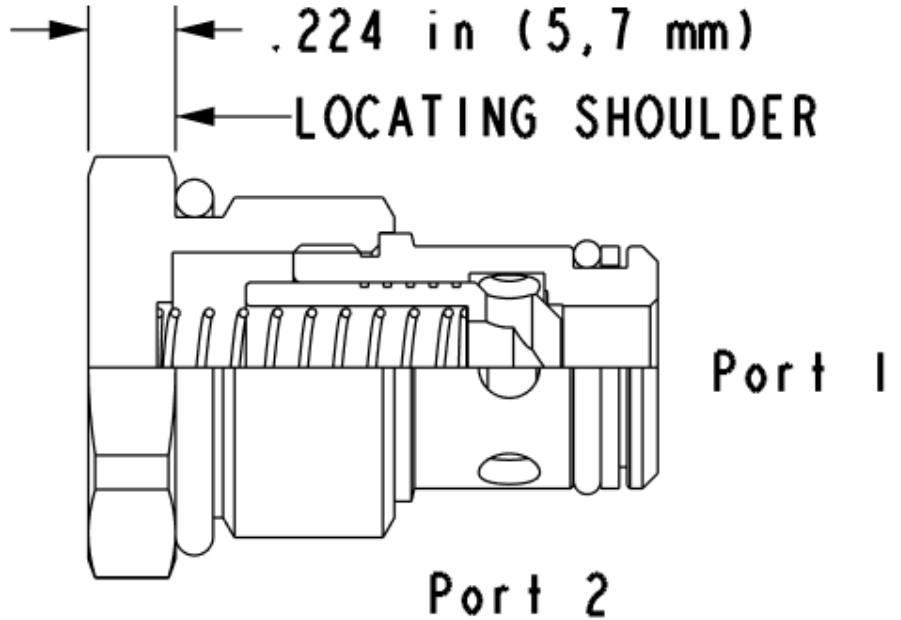

Free-flow, nose-to-side check valves are on/off circuit components that allow free flow from the inlet (port 1) to the outlet (port 2) and block flow in the opposite direction.

**TECHNICAL DATA**

NOTE: DATA MAY VARY BY CONFIGURATION. SEE CONFIGURATION SECTION.

Maximum Operating Pressure	250 bar
Maximum Valve Leakage at 110 SUS (24 cSt)	0,3 cc/min.
Seal kit - Cartridge	Buna: 99C102007
Seal kit - Cartridge	Viton: 99C102006

**CONFIGURATION OPTIONS**

**Model Code Example: CXUTXCN**

CONTROL	(X)	CRACKING PRESSURE	(C)	SEAL MATERIAL	(N)
<b>X</b> -		<b>C</b> 29 psi (2.0 bar)		<b>N</b> Buna-N	
		<b>A</b> 7 psi (.5 bar)		<b>V</b> Viton	